

Suspension Design Considerations: DSA vs SSA

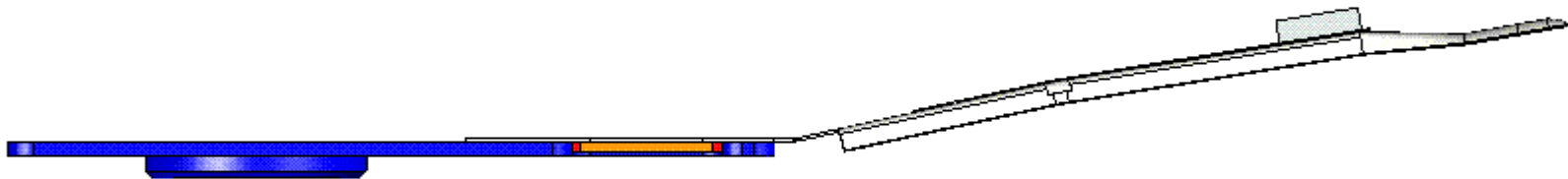

Peter Hahn
K.C. Ee
Amaninder Dhillon

About MPT

Business: Suspensions for HDD

Founded: 1984

Facilities:

Thailand

Wangnoi

Rojana

China

Chang-an, Dong-guan

U.S.A.

Murrieta, California

Corporate Info:

Headquarters – Wangnoi, Thailand

www.magnecomp.com



Wangnoi



Rojana



Chang-an, China

Contents

- Overview
- DSA Types
- Requirements: DSA vs SSA
- Stroke and FRF of DSA vs SSA
- Cleanliness
- Other DSA Considerations
- Summary

Why DSA?

- Enterprise drives improved throughput performance with DSA
- With multiple-platter designs of 3.5” and 2.5”, 400k+ tpi is not easily manageable in meeting TMR budget and various performance targets
- BPI improvement is much more difficult now
- Industry largely exhausted more economical improvement solutions for TPI improvement
 - servo technology
 - butterfly mode control, spindle stability, windage control, dampers etc
 - DSA’s turn now
- In the long run, DSA also supports high TPI required for SMR, BPM and EAMR/HAMR
- DSA is rapidly becoming the standard for new drive products

DSA Adoption Trend

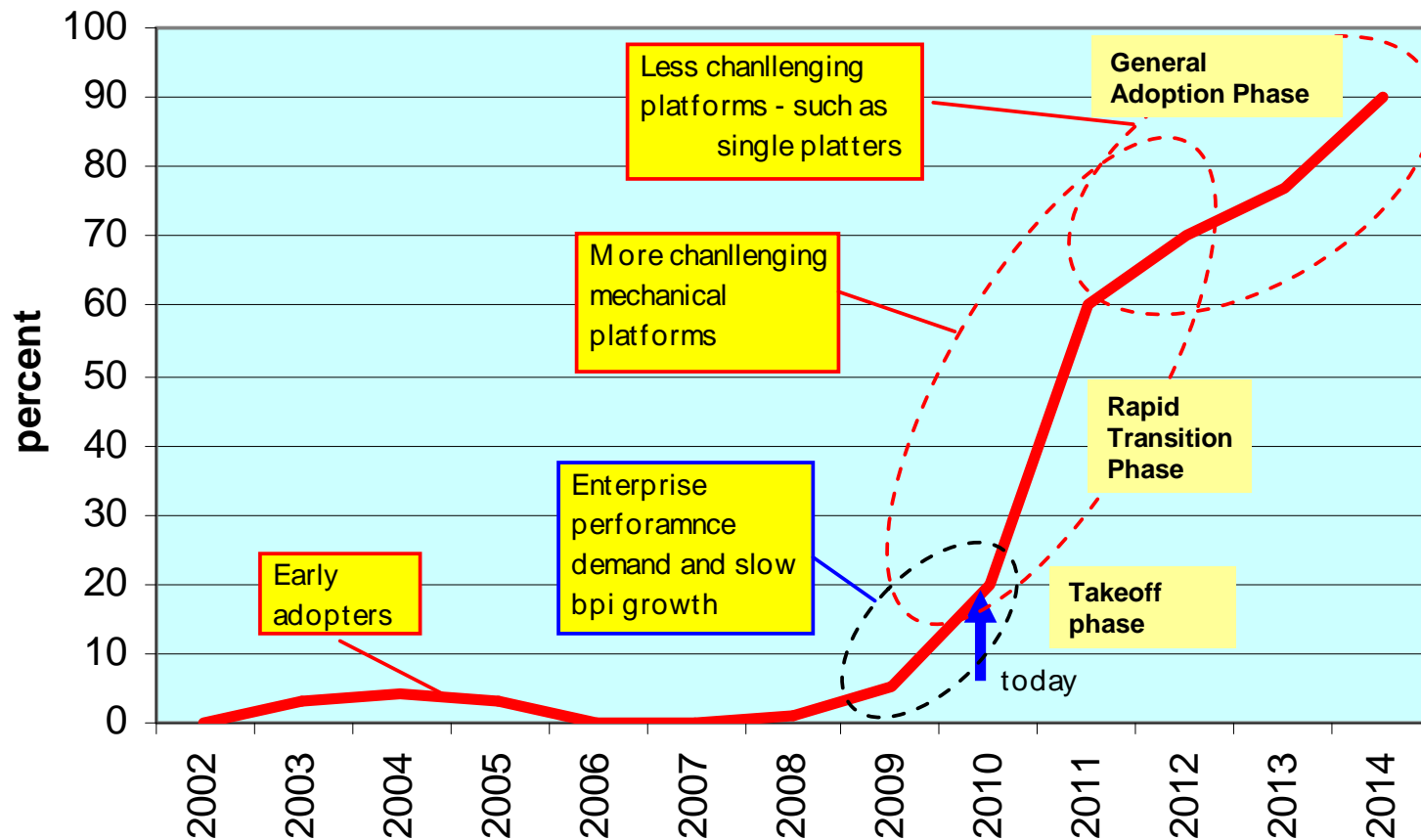

- The on-and-off predictions and experimental implementations turned into a stable migration trend now

DSA Types

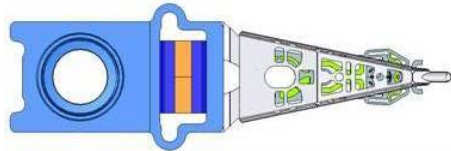

Single PZT on MP

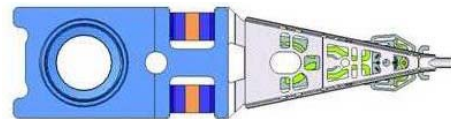

Dual PZT on MP

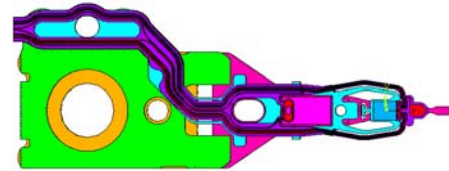

Single PZT on LB



PZT's in Gimbal Area
(shown photo above: CAT)

Platform	PZT's on Mountplate (MP Based DSA)	PZT on Loadbeam (LB Based DSA)	Two PZT's in Gimbal (Gimbal Based DSA)
Application	All	Desktop/Enterprise	All
Advantages	Higher lift-off shock	Less arm mode coupling	Very little arm mode coupling
Limitations	Arm mode coupling	Lift-off shock is not suitable for notebooks	Need slider-rotational type Design optimization is challenging

- Most common DSA style for new products today is *Dual PZT on MP*
- MP based DSA pushes servo BW from SSA's mid/high 1000 to mid 2000 or higher
- Gimbal based rotational type or other improved type of DSA will become a necessity when MP based DSA servo BW is not sufficient
- The rest of this discussion focuses on *Dual PZT on MP*

Dual PZT on MP DSA Example - views

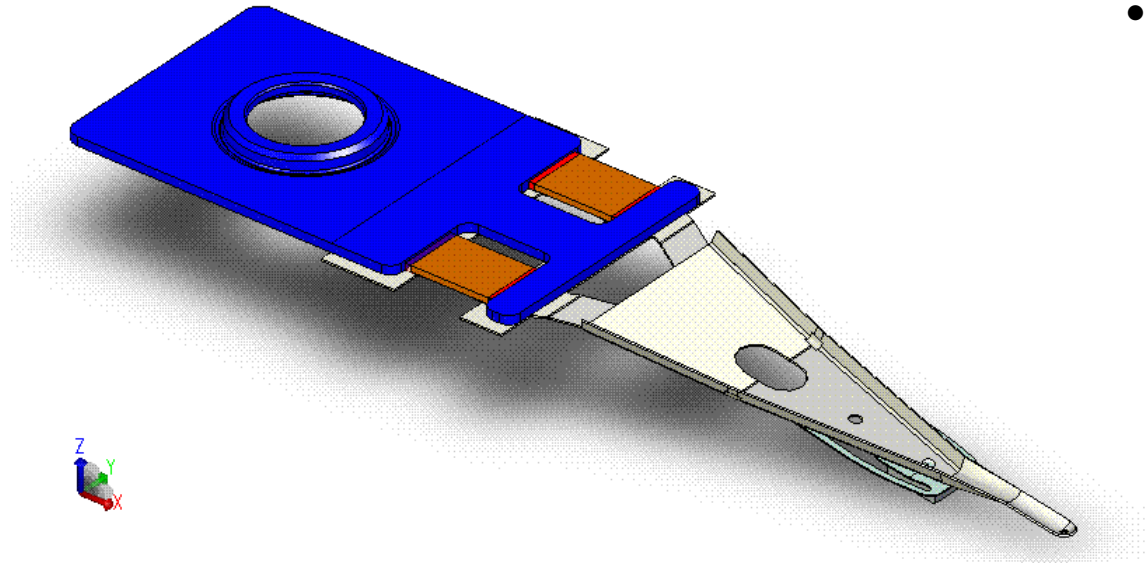

- Example shown
 - 11 mm length: swage boss to gimbal dimple
 - 5.7 mm Loadbeam length
 - 30 μm LB thickness
 - 100 μm PZT thickness

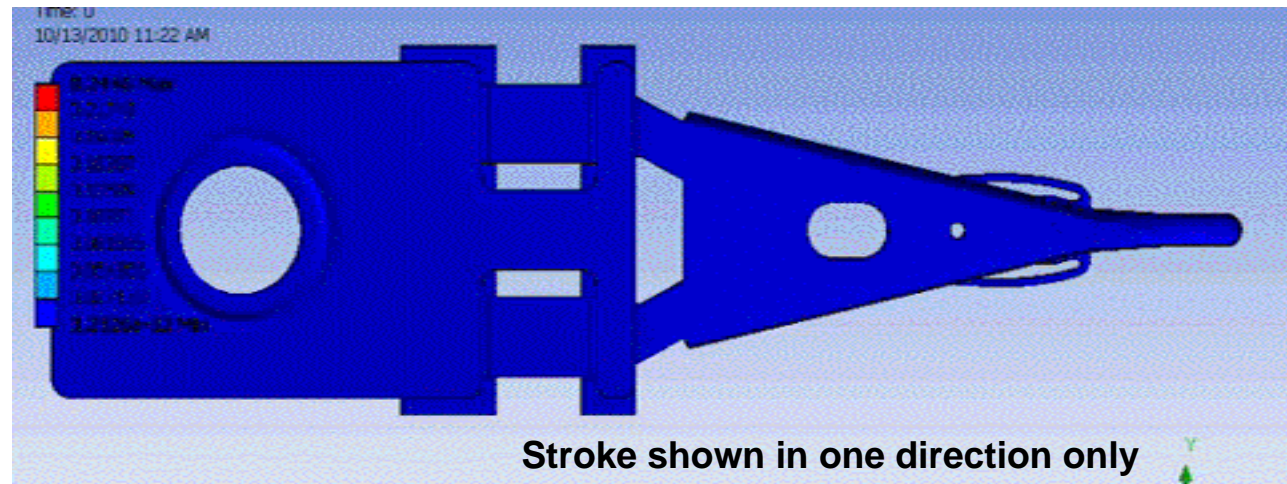

Performance Requirement List – SSA vs DSA

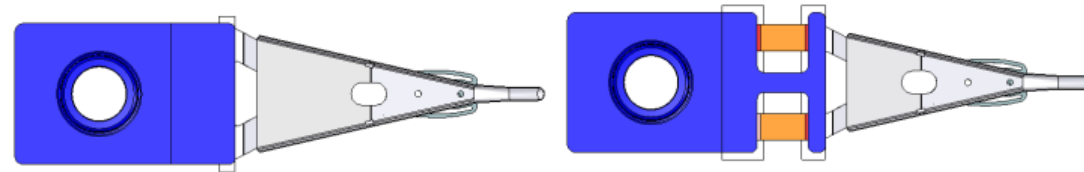

	SSA	DSA
Dynamics	FRF	FRF
Shock	Op shock	Op shock
	Non-op shock	Non-op shock
Stability	Gram stability	Gram stability
	Static attitude stability	Static attitude stability
Environmental Stability (temp/humidity/voltage)	Circuit corrosion	Circuit corrosion
		PZT electrical grounding
		PZT depoling margin
		DSA stroke
Contamination	LPC	LPC
	SST particles	SST particles
		PZT particles

- In addition to the apparent construction difference, the addition of PZT motor function presents more performance items to consider

Typical Design Parameters

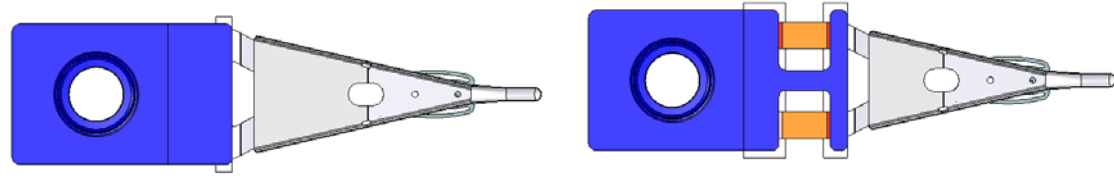

Description	Unit	SSA	DSA
Loadbeam Thickness	um	25 to 100	25 to 30
Mountplate Thickness	um	150-170	150 mostly ¹
Dimple to MP edge	mm	up to 7	5.8 max desirable ²
Free-state Angle	deg	12-14	12-14
1 st Bending Resonance	kHz	5 to 6	5 to 6 ³
1 st Torsion Resonance	kHz	7 to 8.5	7 to 8.5 ³
Sway Resonance	kHz	20 to 25	18 to 22 ³
Hinge Stiffness (Kv)	N/m	20 to 24	20 to 24
Lifter Stiffness	N/m	800 -1300	800 -1300
Static Lift-off Shock	G's/gramf	300-350	300-350
DSA Stroke	nm/V	n/a	10 to 25

Notes:

1. Allows common DSA Motor design for multiple form factors
2. Allows space for PZT in Mountplate
3. Generally, DSA has lower frequency

DSA fundamental

Approximating stroke based on static analysis

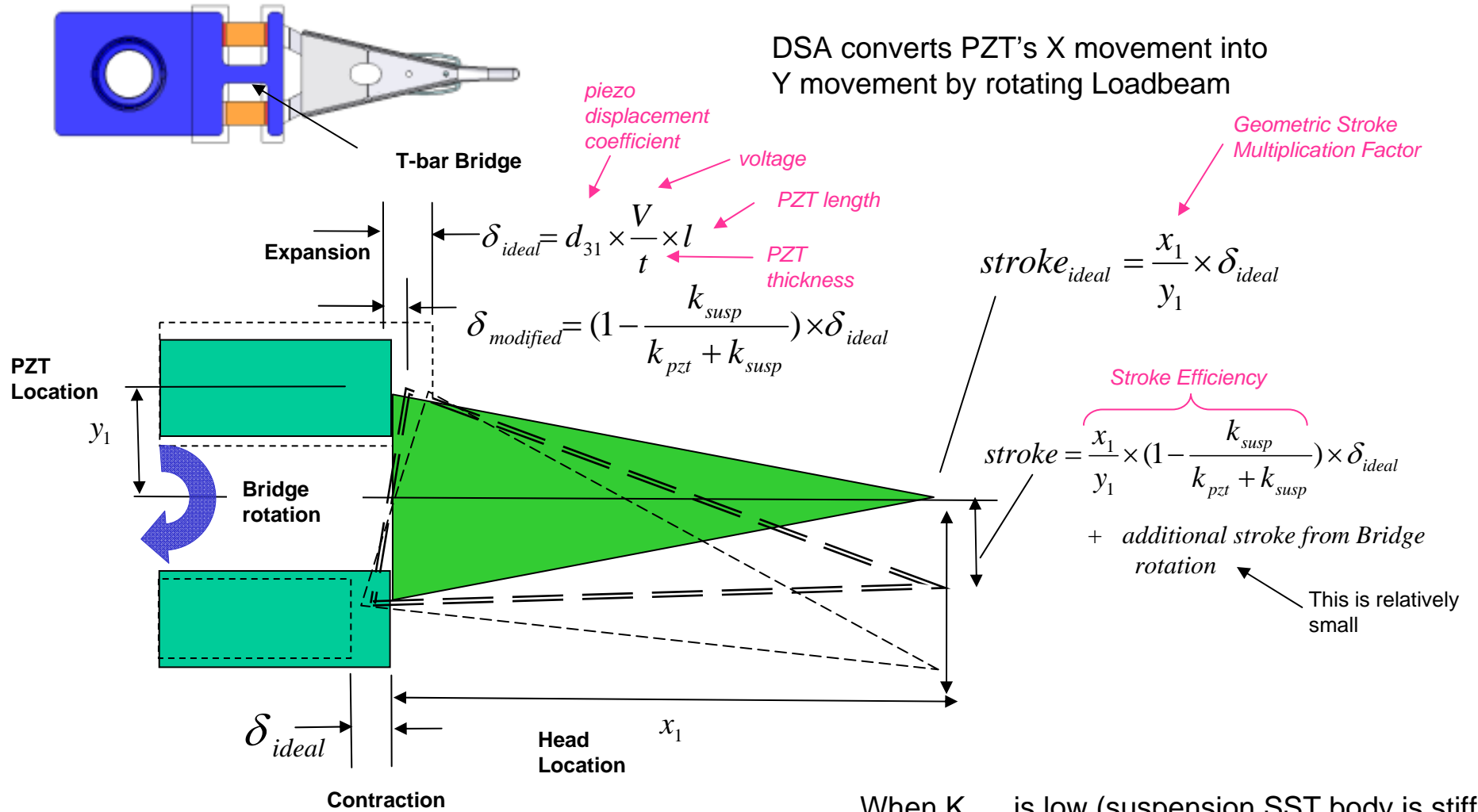

When K_{susp} is low (suspension SST body is stiff)

- Improves Stroke Efficiency
- Lowers Sway Frequency

Stroke and Sway

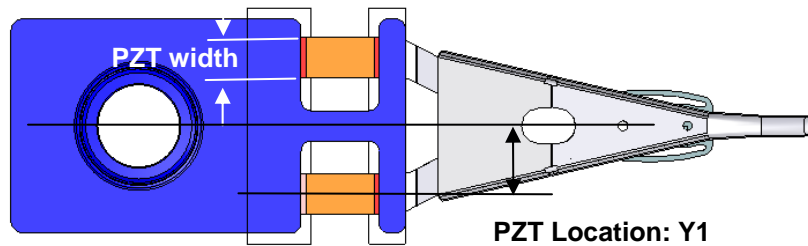

The Support Structure and PZT size/location greatly affects stiffness, stroke and sway

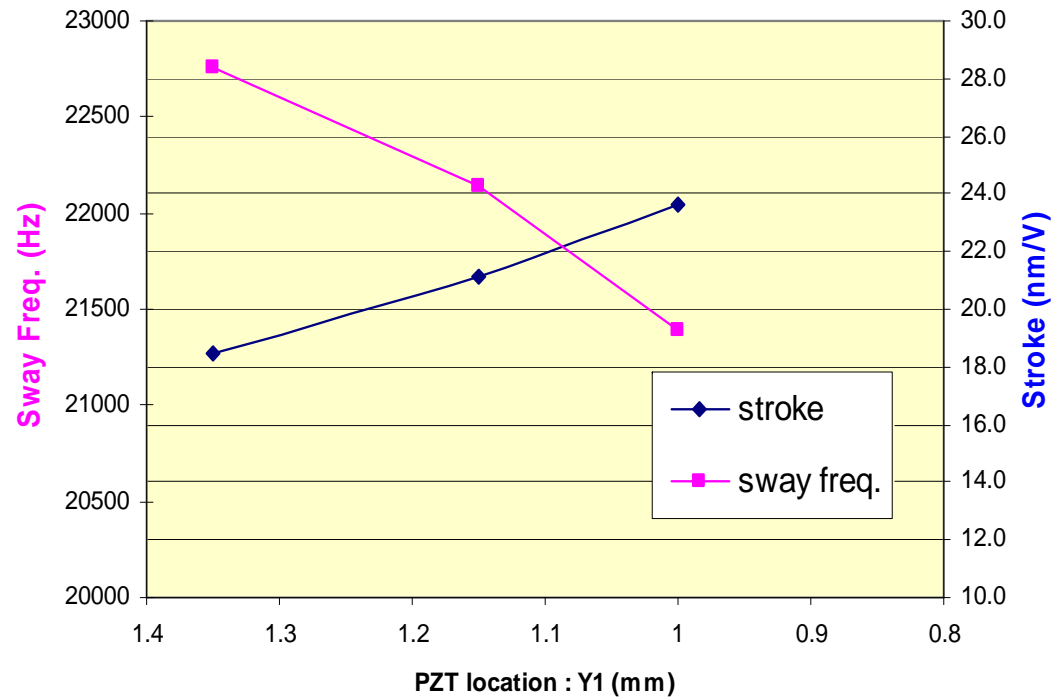

LB Length Effect – LB Shorter for PZT Motor

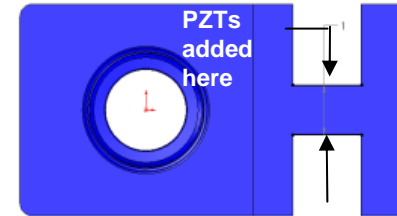
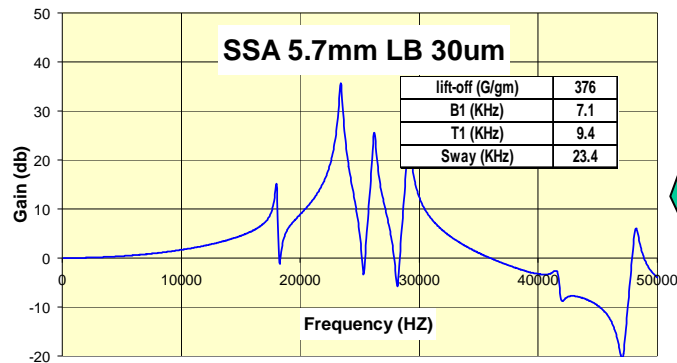
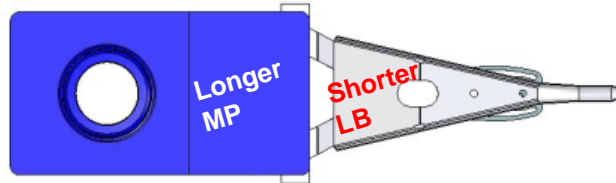
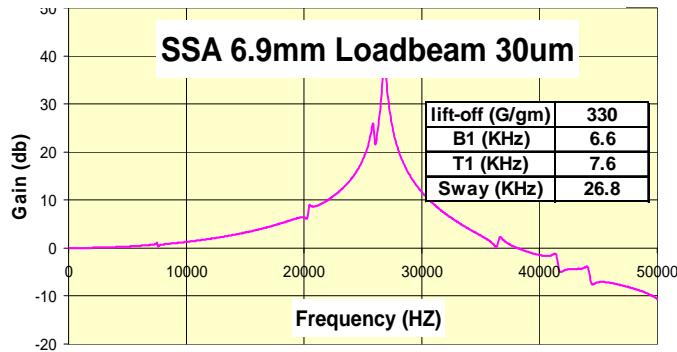
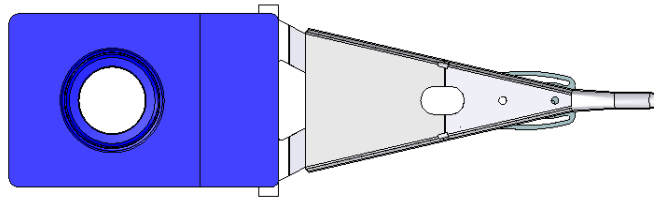

- More interactions between LB and MP
- T2 and T3 become more challenging to control
- Once PZTs are added, structure is somewhat strengthened

PZT Stress

10

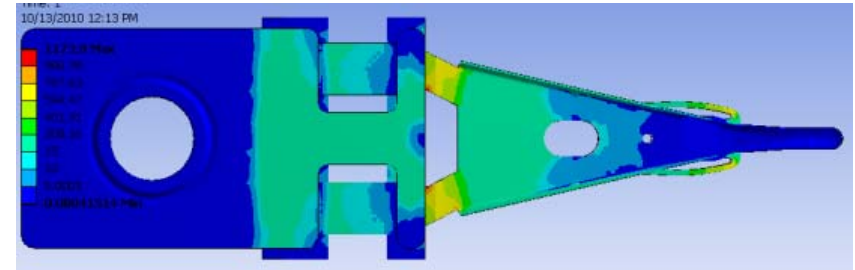
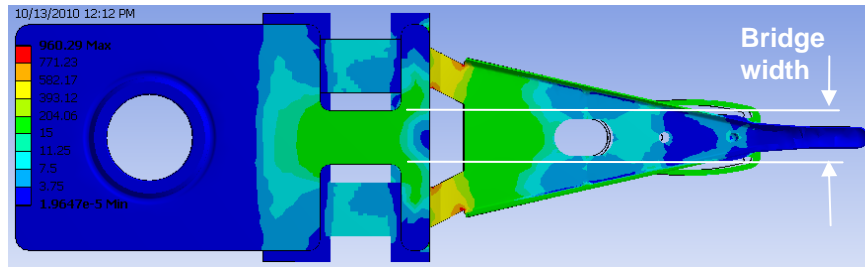

Thicker PZT lowers the stress on PZT, but lowers the stroke

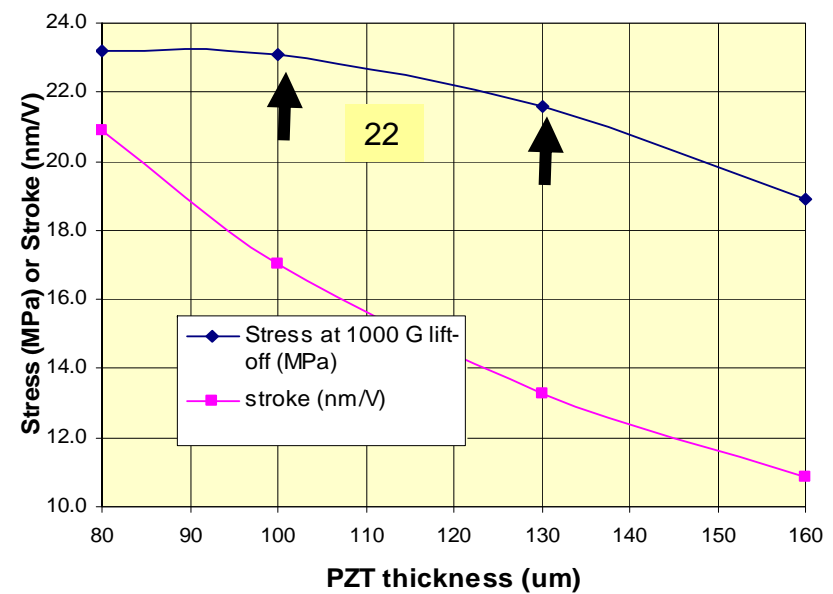
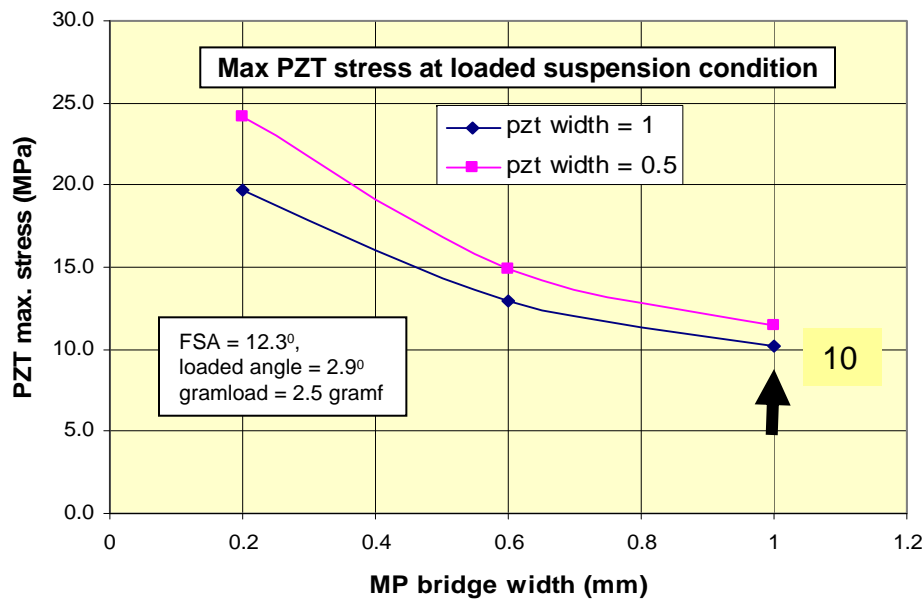

- The tensile strength of PZT is about 80 MPa. → about 100% safety margin with this example
- Needs to verify for the worst case of gramload, applied voltage and op shock.

DSA - Major Mode Shapes

5.7mm LB, 30um thick

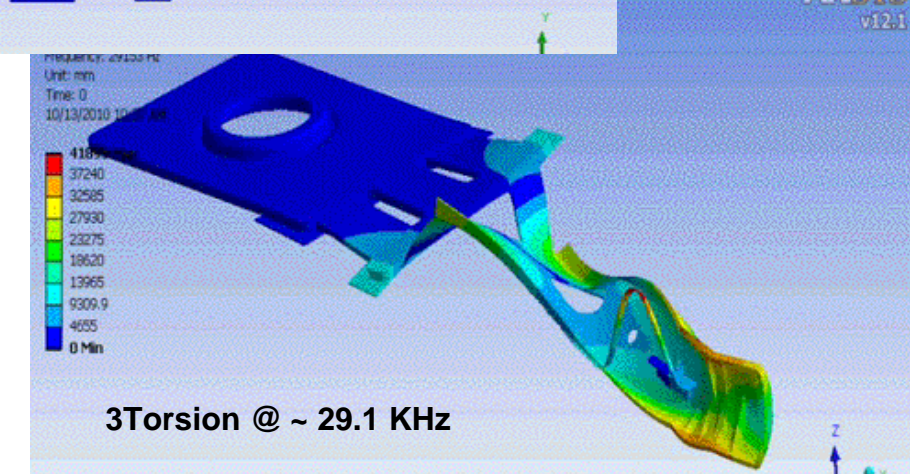
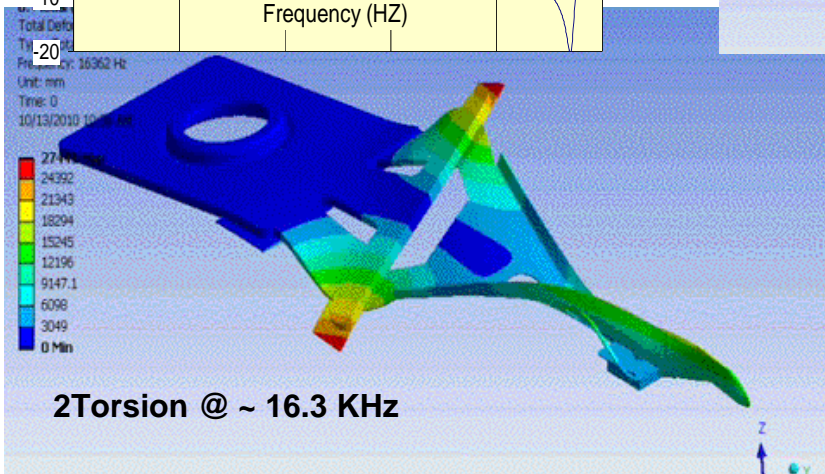
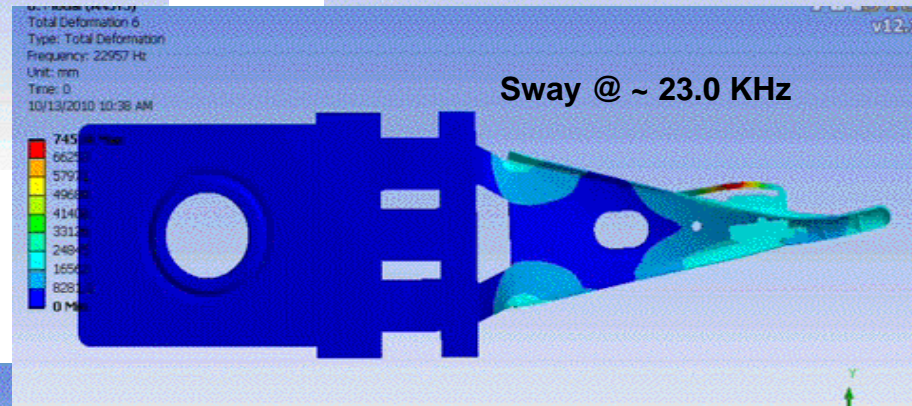
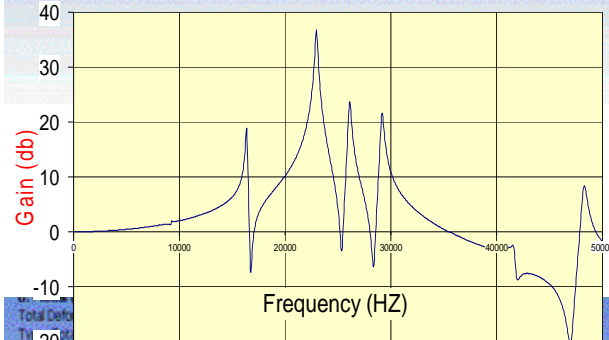
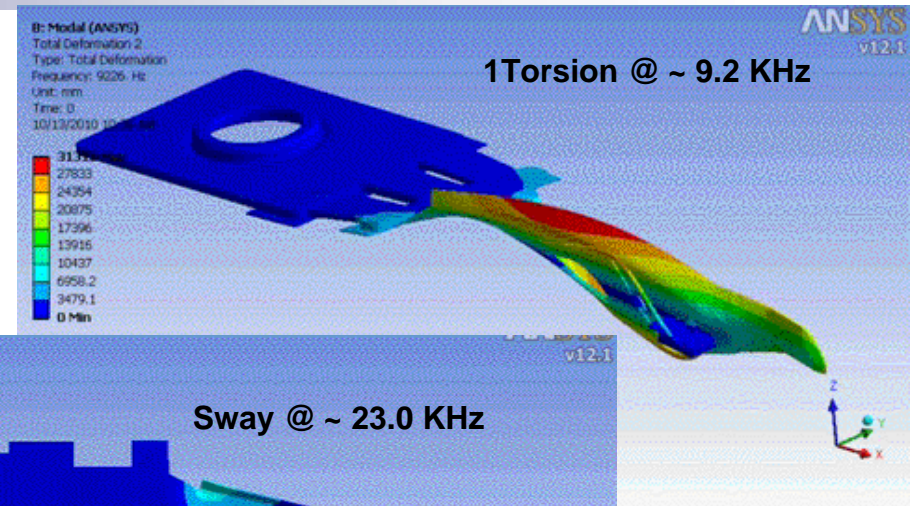
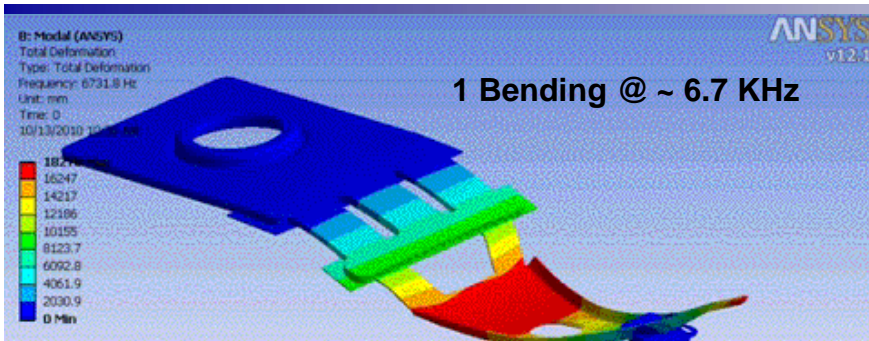

Cleanliness Consideration

PZT is constructed much like concrete

Mix of various materials is cured

Slab is cut to pieces (wafer to dies)

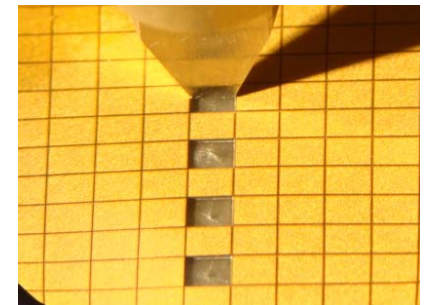

Good in compression mode and not optimal in tension mode

On the cut surfaces, loose grains or particles may be developed, unless treated properly

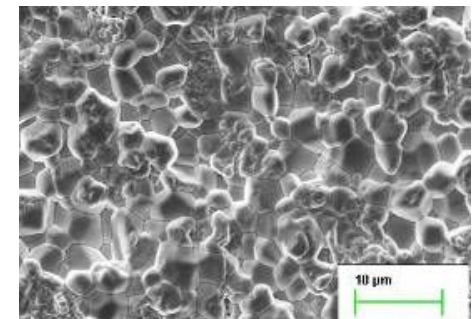
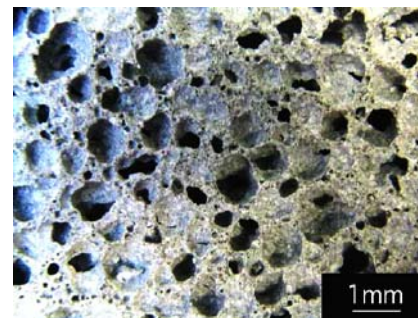

PZT Encapsulation Approaches

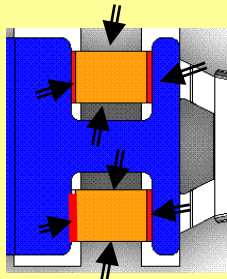
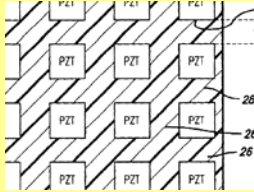
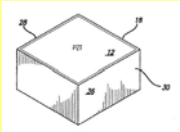
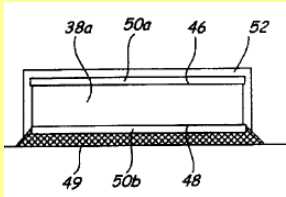
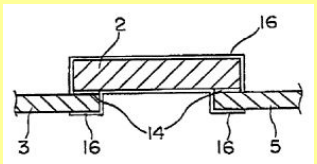
	Epoxy Filling. Suspension Level	Epoxy on Cut Edge. PZT Level	Thin Polymer Coating, PZT Level	Anti-release Material on Cut Face
Patent No	n/a	6,703,767 (MPT)	6,930,861	2002/14815
Description	Epoxy applied to the cut edges after attaching PZTs to suspension body	Epoxy is filled in the gap before dicing PZTs	Thin polymer coating of all PZT surfaces	Vapor Coating of Dysan film
Construction	Add encap material on PZT side walls 	Make gaps and fill them with epoxy  Final dicing – side walls encapsulated 		
Remarks	Provides effective sealing of side walls	<ul style="list-style-type: none"> •Allows more DSA design flexibility •Simpler suspension manufacturing process. 		

MPT supports the first two types of encapsulation in DSA designs

Other Considerations

1. Not all piezoelectric materials are suitable for HDD
 - Ultra high d_{31} PZT's (>350 pm/V), Single crystal PZT's and polymer based piezo (PVDF) have very low Curie temperature
2. Short term temperature exposure for process handling, with typical HDD-grade PZT's:
 - 160°C for DSA
 - ($\sim 220^{\circ}\text{C}$ for SSA suspensions)
3. PZT grounding by conductive epoxy on SST
 - Connection resistance can be reduced by applying electric current through the epoxy interface depending on bond joint features
 - Other solutions are available including added gold plated strip or gold plated mountplate
4. Stroke Sensitivity to driving voltage condition must be verified under long term THB testing

Summary

- HDD industry is transitioning to DSA rapidly
- MP based DSA is most common and Dual PZT on Mountplate is widely used currently
- Addition of PZT motors makes the DSA suspensions behave differently from the SSA type
- DSA design requires careful balancing of Performance and Reliability in FRF, Stroke, Cleanliness and Stability

Magnecomp Precision Technology

- Prepared to support transition to DSA
- Ramping up DSA products to high volume
- Can assist in DSA designs and improving reliability for DSA implementation

- Contact Information
 - Peter Hahn: phahn@magnecomp.com

Thank you